

CABLE DRAG CHAIN : TL SERIES

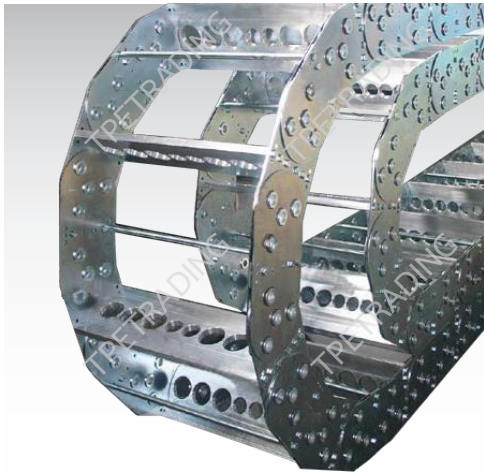

Material	Carbon Steel , Aluminium Alloy, Stainless Steel (Opt)
Inner Height	10 - 175 mm.
Outer Height	25 - 220 mm.
Width	Customized
Colours	Silver, Natural
Working Speed	Max moving speed 40m./Sec.
Noise Volumn	Not greater than 68 db (at max speed)

Cable Drag Chain - TL Series are designed to provide reliable guidance and protection to supply lines and hoses on moving machine parts. A comprehensive range of cost effective drag chains are available at ZDe from plastic mini-energy chains, those which open on one or both sides up to large chains for offshore applications, made from special allow.

Partition Structure

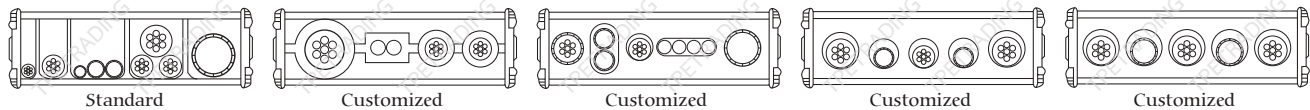

Connection Type

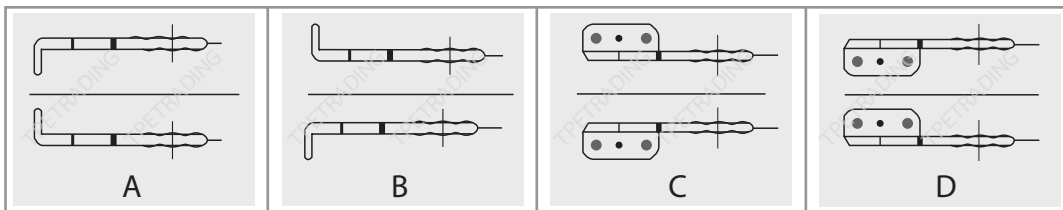

** สำหรับรุ่น TL50, TL65, TL80, TL115 และ TL155 รองรับ Connector เฉพาะ Type D เท่านั้น

TL50

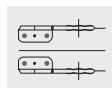
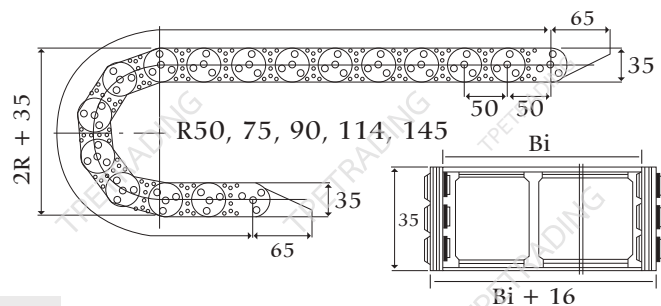

** รุ่น TL50 รองรับ Connector เฉพาะ Type D เท่านั้น

Type	Pitch	Height		Width (Customized)		Inside Max-Hole	Bending Radius
		Inside	Outside	Inside	Outside		
TL50	50	15	35	75	91	-	50, 75, 90, 114, 145
TL50	50	15	35	Bi	Bi+16	-	

TL65

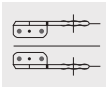
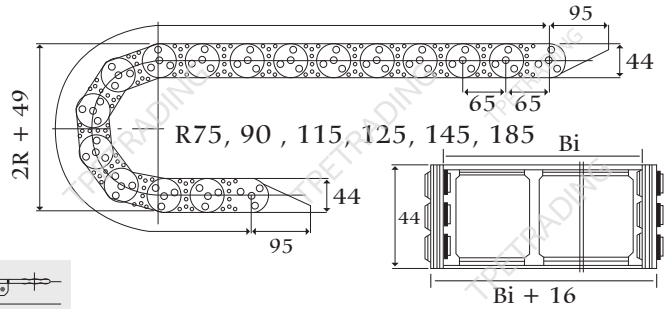

** รุ่น TL65 รองรับ Connector เฉพาะ Type D เท่านั้น

Type	Pitch	Height		Width (Customized)		Inside Max-Hole	Bending Radius
		Inside	Outside	Inside	Outside		
TL65	65	25	44	75	91	30	75, 90, 115, 125, 145, 185
TL65	65	25	44	Bi	Bi+16	30	

TL80

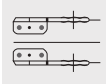
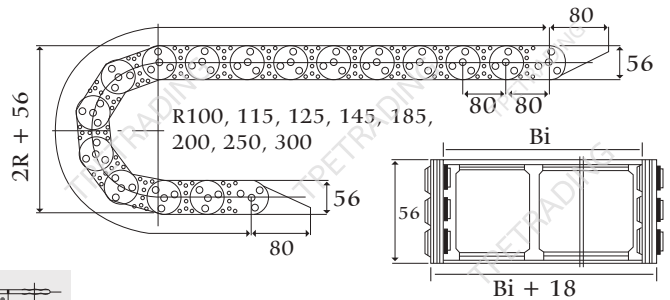

** รุ่น TL80 รองรับ Connector เฉพาะ Type D เท่านั้น

Type	Pitch	Height		Width (Customized)		Inside Max-Hole	Bending Radius
		Inside	Outside	Inside	Outside		
TL80	80	35	56	75	93	35	100, 115, 125, 145, 185, 200, 250, 300
TL80	80	35	56	Bi	Bi+18	35	

TL95

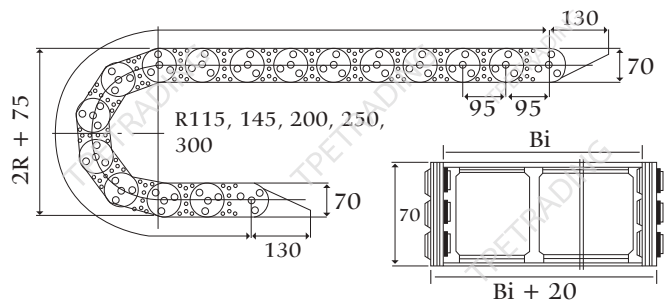
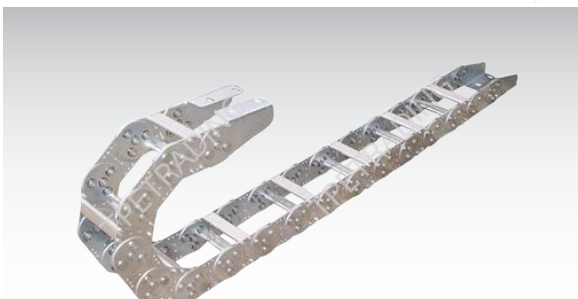

** รุ่น TL95 รองรับ Connector เฉพาะ Type D เท่านั้น

Type	Pitch	Height		Width (Customized)		Inside Max-Hole	Bending Radius
		Inside	Outside	Inside	Outside		
TL95	95	45	70	75	95	48	115, 145, 200, 250, 300
TL95	95	45	70	Bi	Bi+20	48	

TL115

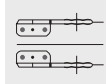
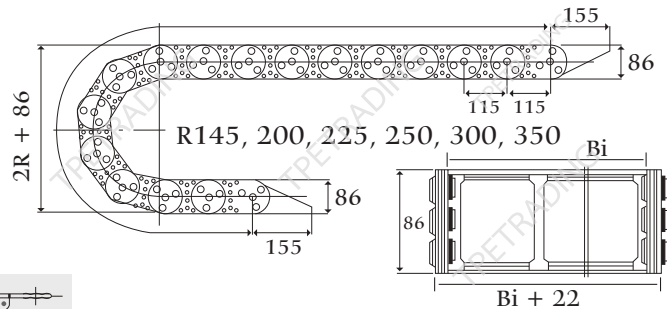

** รุ่น TL115 รองรับ Connector เฉพาะ Type D เท่านั้น

Type	Pitch	Height		Width (Customized)		Inside Max-Hole	Bending Radius
		Inside	Outside	Inside	Outside		
TL115	115	55	86	75	97	63	145, 200, 225, 250, 300, 350
TL115	115	55	86	Bi	Bi+22	63	

TL125

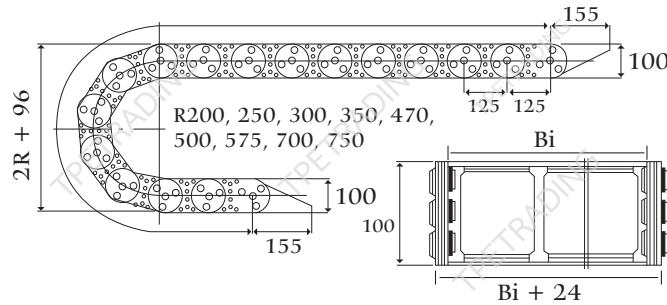

Type	Pitch	Height		Width (Customized)		Inside Max-Hole	Bending Radius
		Inside	Outside	Inside	Outside		
TL125	125	65	100	75	99	68	200, 250, 300, 350, 470, 500, 575, 700, 750
TL125	125	65	100	Bi	Bi+24	68	

TL155

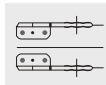
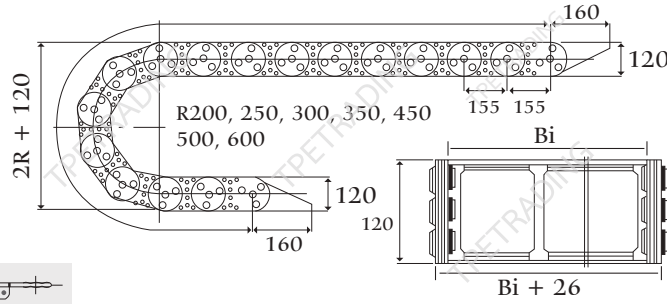

** รุ่น TL155 รองรับ Connector เฉพาะ Type D เท่านั้น

Type	Pitch	Height		Width (Customized)		Inside Max-Hole	Bending Radius
		Inside	Outside	Inside	Outside		
TL155	155	80	120	75	101	97	200, 250, 300, 350, 450, 500, 600
TL155	155	80	120	Bi	Bi+26	97	

TL180

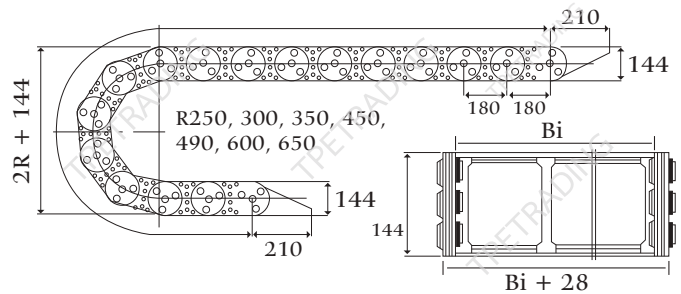

Type	Pitch	Height		Width (Customized)		Inside Max-Hole	Bending Radius
		Inside	Outside	Inside	Outside		
TL180	180	108	144	75	103	110	250, 300, 350, 450, 490, 600, 650
TL180	180	108	144	Bi	Bi+28	110	

TL225

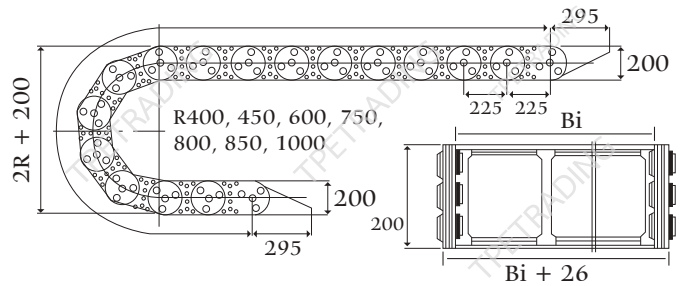

Type	Pitch	Height		Width (Customized)		Inside Max-Hole	Bending Radius
		Inside	Outside	Inside	Outside		
TL225	225	170	200	75	101	146	400, 450, 600, 750, 800, 850, 1000
TL225	225	170	200	Bi	Bi+26	146	

TL250

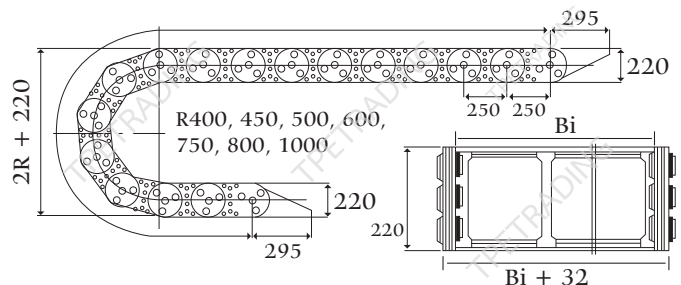

Type	Pitch	Height		Width (Customized)		Inside Max-Hole	Bending Radius
		Inside	Outside	Inside	Outside		
TL250	250	200	220	75	107	166	400, 450, 500, 600, 750, 800, 1000
TL250	250	200	220	Bi	Bi+32	166	