

CABLE DRAG CHAIN : DGT SERIES

The Outer layer of iron plate is stainless-steel (430). It is made of reinforced nylon 66 plus fiber. The iron plate is polished and has the advantages of reasonable structure. high strength. constant shape and exquisite appearance.



Material Stainless Steel , Plastic PA6

Easy to install, It is suitable for all kinds of machine tool machinery and electrical appliances, hydraulic steam line protection and decoration host overall shape. Ensure the safety of operators and enhance the competitiveness of China's machine tools and machinery in the international market.

Specifications and models are as follows :

- (1) such as 1#1200-A-II or 25x45x1200-A-II
- (2) such as 3#1800-CD-III or 45x90x1800-a-III

Please select the specification, model and assembly from A, B, C, D

Assembly diagram

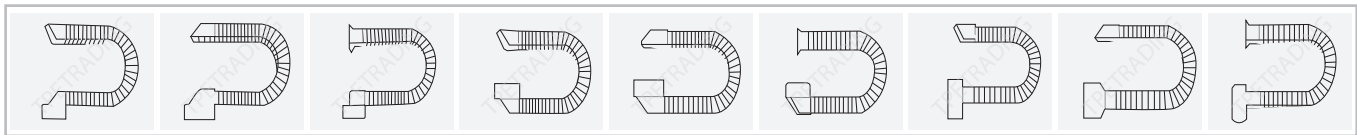

Type A connector Parameter

Spec.	h	b	e	d ₁	l ₁	l ₂
25 x 45	39	57	15	Ø6.5	33	8
38 x 73	53	85	35	Ø6.5	35	10
45 x 90	60	103	40	Ø6.5	40	10
52 x 102	65	114	45	Ø8.5	40	10
60 x 120	75	137	65	Ø8.5	45	10
60 x 150	75	163	80	Ø8.5	45	12
72 x 162	90	180	100	Ø8.5	50	12

Type B Connector Parameter

Spec.	h	b	e	d ₁	l ₁	l ₂
25 x 45	39	57	75	Ø6.5	30	94
38 x 73	53	85	102	Ø8.5	35	120
45 x 90	60	103	130	Ø8.5	40	154
52 x 102	65	114	135	Ø8.5	40	160
60 x 120	75	137	170	Ø8.5	45	197
60 x 150	75	163	210	Ø8.5	45	240
72 x 162	90	180	225	Ø8.5	50	259

Type C Connector Parameters

Spec.	h	b	e	d ₁	l ₁	eh	h ₂
25 x 45	39	57	20	Ø6.5	33	55	77
38 x 73	53	85	35	Ø6.5	35	67	87
45 x 90	60	103	52	Ø8.5	40	78	98
52 x 102	65	114	55	Ø8.5	40	82	102
60 x 120	73	137	70	Ø8.5	45	100	120
60 x 150	75	163	83	Ø8.5	45	103	121
72 x 162	90	180	100	Ø8.5	50	113	137

Type D Connector Parameter

Spec.	h	b	e	d ₁	l ₁	l ₂	l ₃
25 x 45	39	57	22	Ø6.5	38	10	25
38 x 73	53	91	45	Ø6.5	38	10	25
45 x 90	61	108	55	Ø6.5	58	12	35
52 x 102	70	122	70	Ø8.5	58	13	35
60 x 120	81	144	85	Ø8.5	60	15	35
60 x 150	81	184	95	Ø8.5	60	15	38
72 x 162	93	186	115	Ø8.5	64	15	38

Specification Sheet

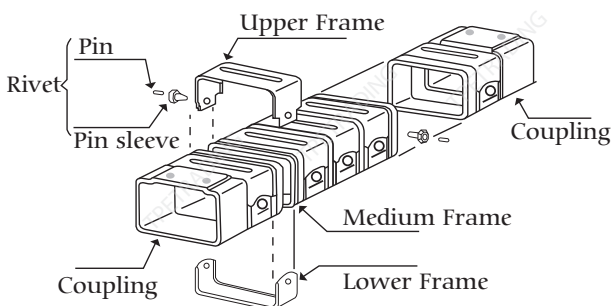

Model	TPE DGT-1	TPE DGT-2	TPE DGT-3	TPE DGT-4	TPE DGT-5	TPE DGT-6	TPE DGT-7
Specification	25 x 45	38 x 73	45 x 90	52 x 102	60 x 120	60 x 150	72 x 162
Appearance	39 x 62	53 x 91	61 x 108	70 x 122	81 x 144	81 x 184	93 x 186
Bending Radius	75	100	130	150	165	165	185
UnSupported Length M	1.5	2.0	2.2	2.5	2.7	2.9	3.0
Load Weight (KG)	3	4	5	8	10	14	20